

THE FACTORY AUTOMATION COMPANY

FANUC

ROBOCUT *α-CiB* series

High-Precision CNC

Wire Electrical Discharge Machining



Extremely versatile wire EDM,
plus an 800 mm table and
an option for a Z axis travel
of 500 mm

WWW.FANUC.EU

intelligent automation – 100% FANUC

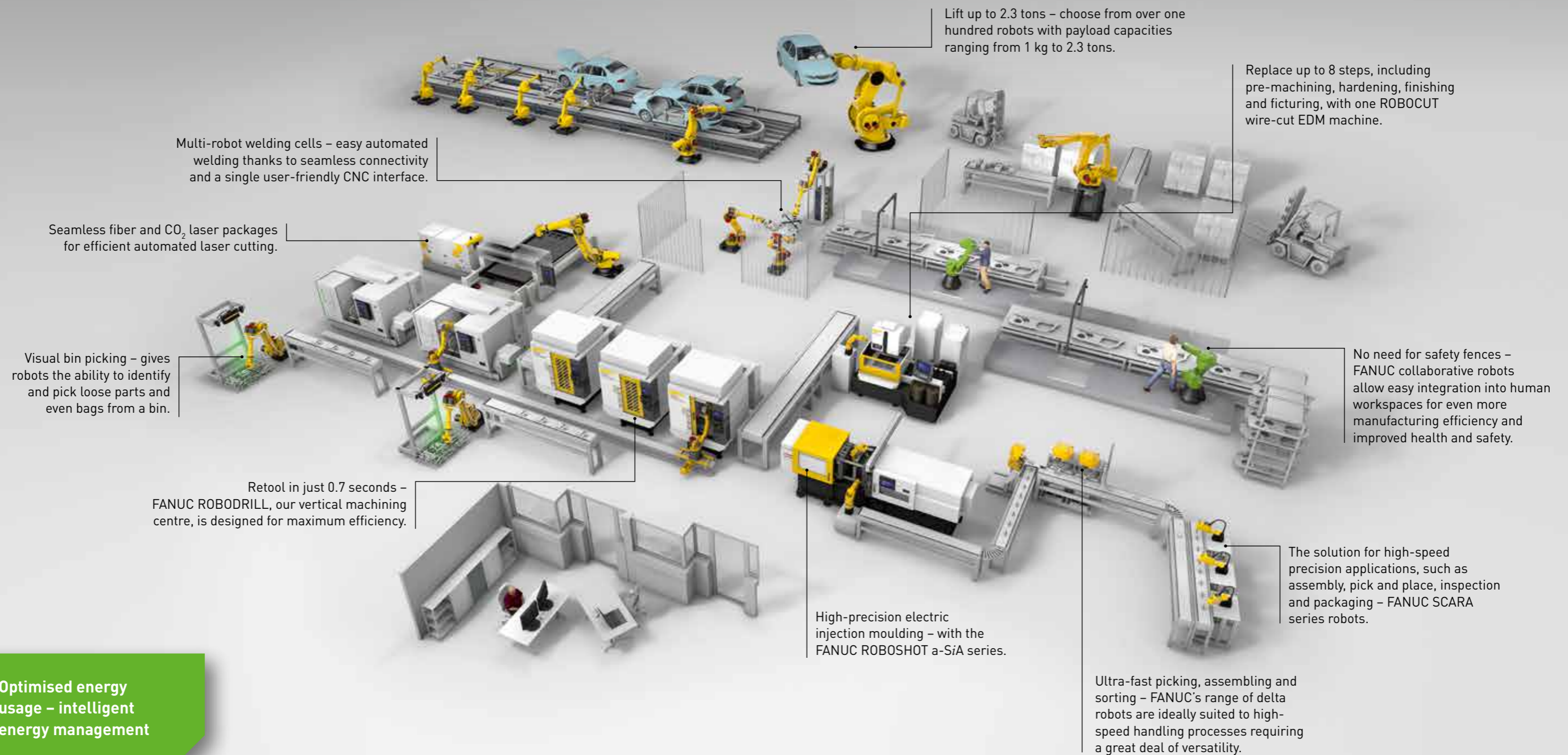

Optimised energy usage – intelligent energy management



With three core product groups, FANUC is the only company in its sector to develop and manufacture all its major components in-house. Every detail, both hardware and software, undergoes stringent quality control checks as part of an optimised chain. Fewer parts and lean technology make FANUC solutions reliable, predictable and easy to repair. They are made to run and provide you with the highest uptime on the market.



All FANUC products – industrial robots, CNC systems and CNC machines – share a common servo and control platform, providing seamless connectivity and making full-automation scenarios really simple. Since all products share common parts, spare parts management with FANUC is fairly efficient. Plus, global standards make it very easy to go international with FANUC.

ROBOCUT – fast, accurate, multipurpose EDM

Where wire EDM is concerned, accuracy has traditionally come at the cost of speed. That's why FANUC has developed a next generation ROBOCUT wire EDM machine. The α -CiB series comprises three versatile all-rounders, including the first model with an 800 mm table and an option for a Z axis travel of 500 mm. With incredibly long mean times between failures, low maintenance, longevity and excellent uptimes, these future-proof machines are designed to save time and drive down unit costs while ensuring superlative accuracy and cutting.

Designed for ultimate performance

- latest CNC and servomotor technology
- generator designed for maximum reliability
- capable of cutting thick, stepped and tapered parts
- multi-workpiece cutting
- easy-to-use CORE STITCH Function for even longer unmanned machining
- wire threading in just 10 seconds
- automatic in-path wire re-threading
- accurate twin servo wire tension control

Flexible discharge pulse generator (FPC)

FANUC has developed a more powerful flexible circuit board to precisely control and shape discharges according to actual machining conditions. Thanks to the new Flexible Pulse Control, Pulse Modes are now available to reduce cycle times and increase accuracy. These new sets of process parameters are specifically developed and optimized to cut thick parts and taper angles up to 12 degrees that can guarantee excellent results also in open nozzle cutting conditions.

Faster positioning

The Smart Positioning function gets you started faster by cutting the time it takes the machine to measure geometrical references on the workpiece. FANUC uses wire touching to find the desired wire-workpiece relative position; the Smart Positioning function sets parameters and the machine automatically finds the starting point. In the new ROBOCUT series this function has been improved, reducing hole positioning time by as much as 30 % compared to the previous ROBOCUT series, and at no cost to accuracy.

Higher body rigidity for maximum accuracy

ROBOCUT's ultimate frame design is the result of advanced FEM (finite element method) analysis that was validated through extensive tests on full-size prototypes for ultimate machining accuracy. As a result, high accuracy machining can be achieved on every model in the range and under varying environmental temperature conditions.

40 years of
ROBOCUT
technology
designed and built in Japan

Unbeatable wire EDM versatility

A versatile all-rounder, the FANUC ROBOCUT will do 80 % of your everyday cutting tasks without you ever needing to change the set up. When you do though, you will find that ROBOCUT's extensive range of options make adapting it extremely straightforward.



Easy-to-set CORE STITCH function

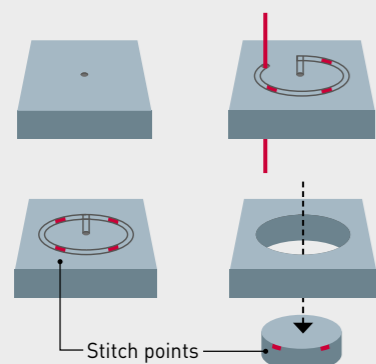

ROBOCUT α -CiB series allows you to extend unmanned machining hours by better planning cutting jobs. Stitch points are set directly on the machine's CNC without any pre-programming. Used in combination with the re-threading in the wire path function, it is the ideal solution for long lasting unmanned machining and multi-workpiece cutting processes. When the job is done you simply knock out the cores manually without any risk of damage to the machine. It is now possible to remotely program stitch points through user-friendly ROBOCUT CAMi software via your desktop.

New model with rigid 800 mm table for even more versatility

Efficient versatility

Able to machine parts of up to 1250 x 975 x 500 mm, the ROBOCUT α -C800iB is a future-proof answer to an unpredictable market: should workpiece design change suddenly, this machine can keep up.

Efficient space saving

Big but compact, the ROBOCUT α -C800iB has the smallest footprint and lowest height in its class – it's your perfect space saving solution.

Versatile unmanned machining

The α -C800iB model allows you to mount multiple pieces with just one set up and also offers the most advanced CORE STITCH function on the market, saving you time and driving down your unit costs.

Features and benefits of the efficient all-rounder

Capable of tackling a wide range of jobs, ROBOCUT comes with a wealth of features designed to help you adapt quickly to new demands and cutting specifications. Whether it's programming, setting up, machining or maintenance, ROBOCUT adds that extra bit of efficiency you need to stay competitive.

Unique pre-seal self-cleaning

Reducing cleaning times to less than an hour a week and helping to maintain accuracy, this separable unit comes with a patented pre-seal system that prevents sludge from adhering.



Faster set up

FANUC's Set up Guidance function ensures ultra fast set ups and reduces downtime by flagging potential operator errors. Other timesaving features include an automatic front door and a partial drain workpan that reduces turn around times by allowing you to remove parts without completely draining the tank.



Accurate machining despite temperature fluctuations

Thanks to its AI Thermal Displacement Compensation feature, ROBOCUT consistently machines to the same standards despite room temperature fluctuations. FANUC now offers a 3-sensors solution for environments with high temperature fluctuations and a 7-sensors solution specifically designed for minimal displacement adjustment on machines installed in temperature-controlled rooms for higher precision.



Easy maintenance

Maintenance is easy thanks to an automatic front door and a work table that allows access to the table from below. A clear and precise maintenance guide ensures correct maintenance can be carried out in just a few steps.



Optimal workspace utilisation

Depending on the model, ROBOCUT's U and V axes can be traversed 90 mm beyond the table, leaving 10 mm between the wire midpoint and the inner edge of the table. This enables smaller workpieces to be machined without the need for expensive clamping devices.



Fully automatic filling level control

ROBOCUT measures the water pressure at the bottom of the tank and regulates it according to the Z-axis position using a servomotor. As a result, you benefit from fewer parts, less maintenance, more reliability and an accurate water level within the workpan.



iPulse2 Discharge Control

Minimises the risk of wire breakages at high machining speeds, even under difficult conditions such as those involving wide nozzle distances or changing cutting heights.

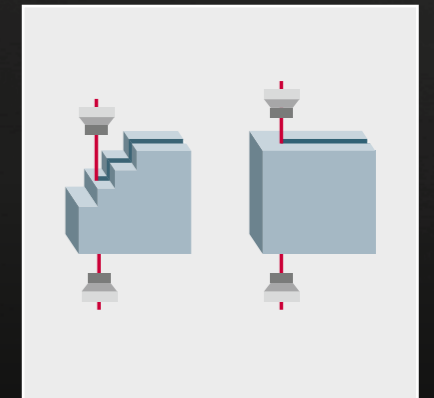

Automatic threading in just 10 seconds

FANUC's unique AWF3 Automatic Wire Feed threading technology provides fast, reliable automatic threading in just 10 seconds. To ensure reliable threading and re-threading, wires are cut electrically leaving a pointed end that is absolutely straight and burr-free, even on soft wire. Aided by a jet of water, threading the wire is both simple and very fast.

140 hours of unmanned machining

With 60 hours of wire as standard, the 30 kg spool option and wire cutter more than double the period of continuous operation.

Reliable re-threading in the wire path

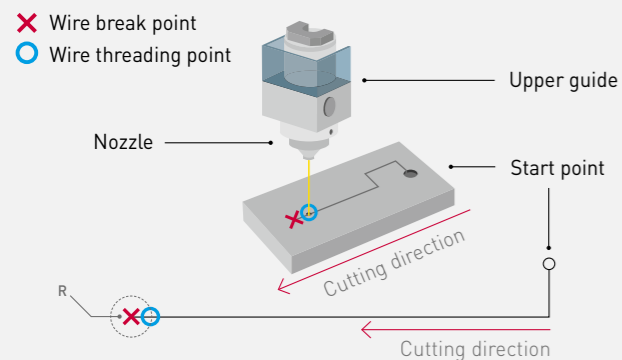

Unlike other machines, ROBOCUT does not need to return to the starting point after a wire break. This radically reduces machining times by re-threading automatically in the wire path on workpieces up to 150 mm thick – even on challenging micro-machining orders.

Consistent wire tension – improved overall reliability

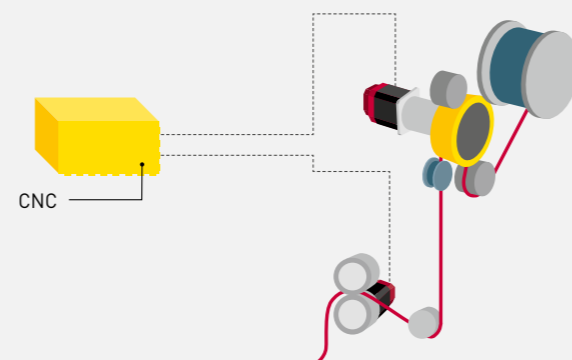

Two servomotors maintain the wire tension of your ROBOCUT to +/- 15 g of accuracy. Made possible by FANUC's digital servo technology, FANUC's unique twin servo wire tension control ensures consistent cutting by compensating for wire errors. Additional benefits are fewer wire breaks and reduced parts wear.

Built-in efficiency

- supremely reliable submerged threading and re-threading even on thick workpieces up to 500 mm
- accurate taper-cut threading up to a height of 50 mm and taper angle of 5 degrees
- soft wire AWF option to achieve straight burr-free cut ends on soft wire
- AWF mechanism easy to dismantle, clean and reassemble

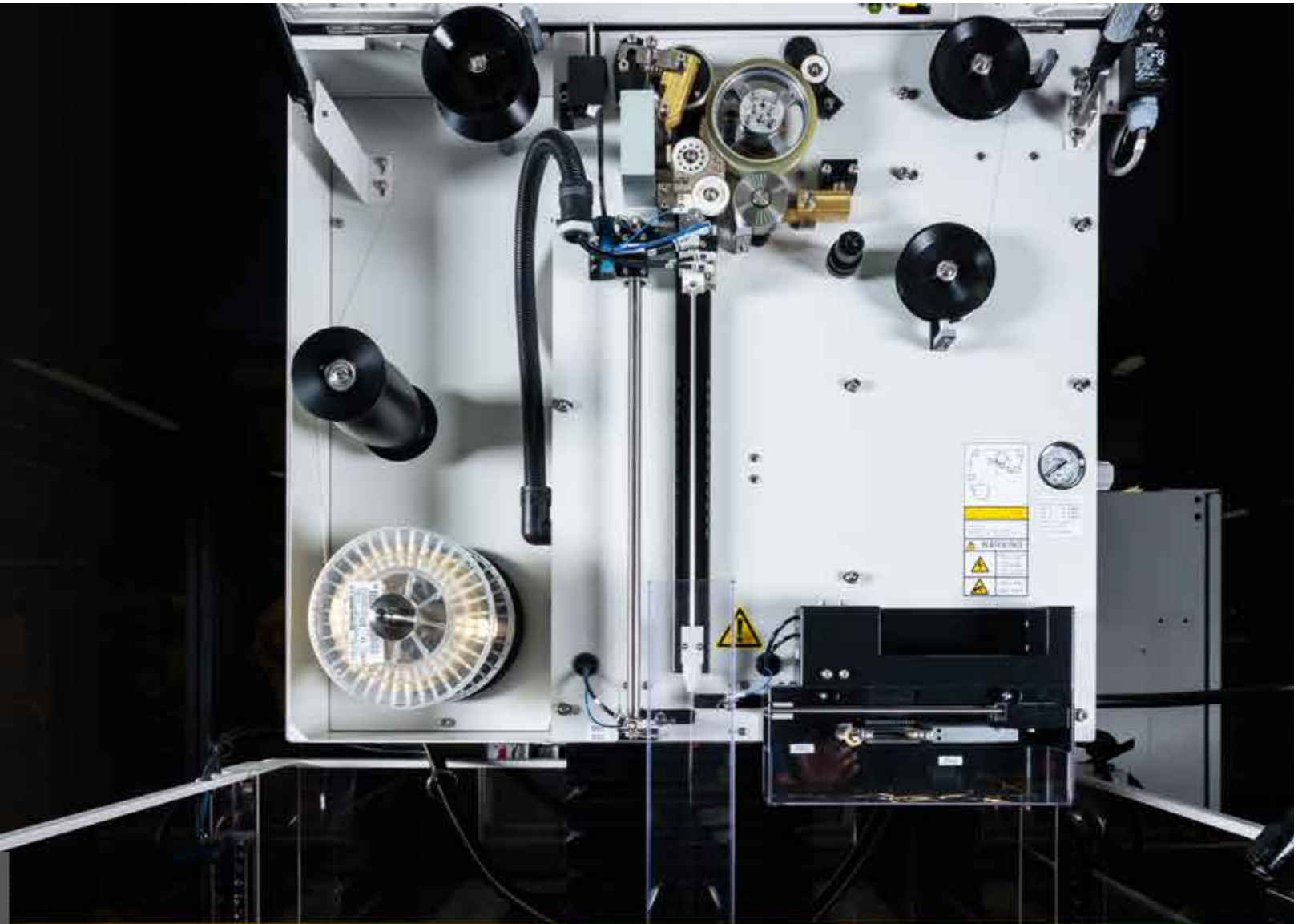
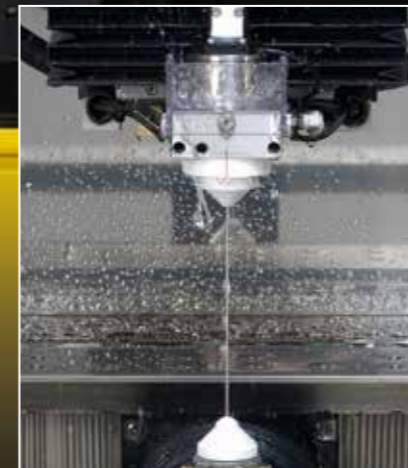

Cutting-edge CNC

The centrepiece of every FANUC ROBOCUT is the most reliable CNC in the world. Designed for maximum precision, FANUC CNCs are extremely easy-to-use and program and offer unrivalled functionality. To date over 4.1 million units have been installed worldwide. To achieve exacting results on more demanding cutting operations, the FANUC 31i-WB High-Performance Control supports up to 7 simultaneously controlled axes and, by monitoring them constantly, ensures continuous protection against collisions. Programming the 31i-WB is simple, with the control's power save mode and energy recovery features making ROBOCUT especially cheap to run.

easy-to-use, lightweight pendant control

- fast auto diagnosis
- accurate auto correction
- precise predictive maintenance
- easy auto programming
- easy-to-use control screen
- supports multiple languages

- easy-to-clean membrane keyboard
- fibre optic cable for maximum reliability
- energy saving switching electronics
- mouse and keyboard interface
- predefined shortcuts
- keyboard and touchscreen

- 15" colour touchscreen display
- intuitive iHMI home screen
- quick and easy data input
- improved interface to robot operation screen

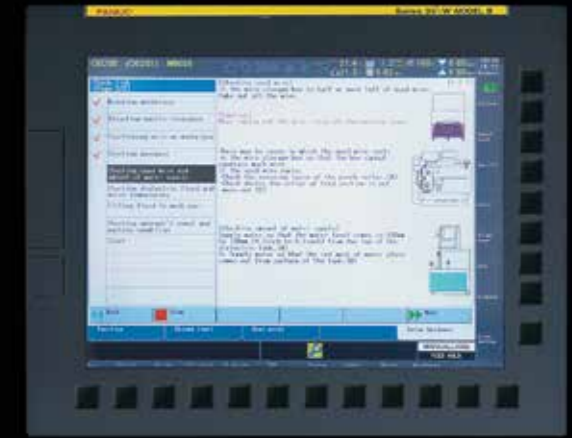

No more downtime: simple maintenance – early detection

The intuitive visual maintenance interface on FANUC's 31i-WB CNC facilitates faster recoveries after servicing. The integrated early warning system identifies errors before they occur, ensuring maximum precision and consistent quality standards.

- Ethernet interface
- USB interfaces
- CF card slot
- RS232C interface



Remote monitoring with ROBOCUT-LINK*i*

Equipped with a new graphic interface, ROBOCUT-LINK*i* is an updated production and quality information management tool that allows you to monitor the status of up to 32 ROBOCUT machines in real time from remote PCs or smart devices. Specific information is available for each cutting job, and event driven push notifications can be sent to different devices. The extremely user-friendly and intuitive interface gives you access to preventive maintenance functions, estimated consumables levels and recently occurred alarms list. It also allows you to transfer NC programs and run quality checks by comparing standard data to current cutting statuses. The ROBOCUT-LINK*i* program manager function has been updated with a refreshed graphical user interface and advantages in usability and flexibility: the program manager is now easier to use, can transfer programs and subprograms at once and can be operated from any connected device such as a smartphone. Furthermore, the new QSSR overview function is an automated system management tool that enables live status on-line monitoring of several ROBOCUT machines and robots in a single view.

Status monitor

- layout monitoring
- device detail monitoring

Operation results

- group operation results
- device operation results
- machining results

Diagnosis

- alarm history
- program history

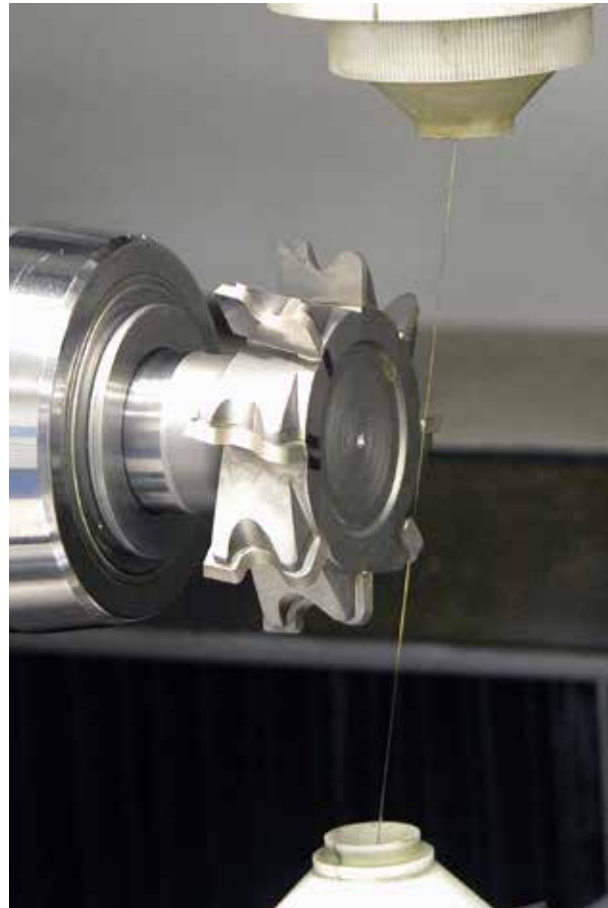

The perfect package for PCD tool making

ROBOCUT α -CiB series machines take Polycrystalline Diamond (PCD) tool making a step further due to the ROBOCUT PCD Generator which ensures that the crystals remain intact during the cutting process. It provides high-speed precision machining for tool sharpening and makes it possible to process extremely difficult to cut PCD and CBN grades. Furthermore, FANUC ROBOCUT is available with a CCR rotary table, which improves cutting complex PCD tools through high-resolution glass scales. Capable of cutting at a variety of different angles, ROBOCUT is ideal for sharpening bonded PCD blanks. Moreover, the Flexible Pulse Control minimises the risk of wire breakages at high machining speeds, even under difficult conditions and therewith guarantees surface integrity.



Designed for easy automation

Easy robot access for loading heavier workpieces as well as an ergonomically designed work area ensure trouble-free machine tending. FANUC's comprehensive network of dedicated European partners possesses the technical know how to provide a solution that is tailored to your specific automation needs. All FANUC products speak the same language and share a common servo and control platform – something that makes learning and operation extremely easy. Additionally, third party automation systems can seamlessly connect to FANUC machines through the new robot interface.

FANUC ROBOCUT for the automotive industry

Mass producing parts for the automotive industry demands incredibly high levels of reliability and efficiency from machines. These need to deliver repeatable accuracy over extremely long periods of time. ROBOCUT not only offers up to 140 hours of unmanned machining but also provides incredible accuracy and superior surface finishes on demanding workpieces, such as moulds, that require sophisticated shapes to be cut to very tight tolerances. What is more, ROBOCUT's CCR rotary table is ideally suited to PCD tool cutting and producing the sophisticated components and rotary tools often required in the automotive industry.

Automatic wire threading

To ensure seamless cutting on non-stop production runs, ROBOCUT's automatic wire feed (AWF3) automatically rethreads the wire in case of breaking. It does this submerged in the cutting gap and so dispenses with the need to drain and refill the water tank.

PCD tool cutting

PCD wire cutting offers considerable advantages over diamond grinding. Edge quality is excellent, running costs are low and sophisticated profiles can be cut to incredible degrees of accuracy in just a few cutting cycles.

FANUC CCR rotary table

For maximum precision and versatility, this compact, lightweight universal positioning table comes with high-resolution glass scales and for maximum concentricity provides optimum travel between the U and V axes.



FANUC ROBOCUT for the electrical and IT parts industry

Extremely high accuracy on tooling, such as moulds, is needed to make high precision and micro parts such as electrical connectors. Incredible levels of repeatability also ensure the same high standards are obtained time and time again.

Thin wire cutting

Ideally suited to cutting minute parts, ROBOCUT's thin wire functionality makes it possible to cut with wire down to 0.05 mm in diameter. This makes it possible to produce the very small and thin parts, such as connectors and semi-conductors, required in the electrical and IT industries.

MF2 micro finish function

FANUC's MF2 micro finish generator not only enables you to achieve extremely fine surfaces and mirror finishes but also ensures maximum accuracy and efficient cutting. This is ideally suited to producing the moulds used in electrical injection moulding to make high quality electrical components such as connectors.



FANUC ROBOCUT for the medical industry

When equipped with a FANUC rotary table, ROBOCUT offers the flexibility to machine the extremely sophisticated shapes required in the manufacture of medical and surgical equipment. ROBOCUT also delivers the high levels of reliability and repeatability required to mass-produce equipment for the medical industry.

FANUC CCR rotary table

For maximum precision and versatility, this compact, lightweight universal rotary table comes with high-resolution glass scales and for maximum concentricity provides optimum travel between the U and V axes. Saving time on machining processes by dispensing with the need to manually rotate the workpiece, FANUC CCR rotary table is ideally suited to the production of medical products. It is perfectly insulated to avoid water entering and comes with flood detection as standard.

Quick quality check

Designed to ensure consistent output, ROBOCUT-LINKi software detects faults in finished items to incredible degrees of accuracy, no matter how many items there are in a batch. Thanks to this software, if one of them is faulty, this tool will find it.

Automatic wire threading / re-threading

Enabling up to 140 hours of unmanned production, this feature is a real advantage on medical sector applications, saving labour costs and fully automating the seamless mass production of components.



FANUC ROBOCUT for job shoppers and mould makers

ROBOCUT is a versatile all-rounder that does just about everything. Its low running costs and ability to machine sophisticated parts to incredible degrees of accuracy make it perfect for general machining work. Available with an 800 mm table, it provides future-proof design and multipart machine capabilities that are ideally suited to producing prototypes or high-value parts of up to 1250 x 975 x 500 mm. Additionally, its unrivalled CORE STITCH function can be programmed easily on the shop floor without a PC and ensures ultimate reliability for jobs that require long unmanned processing times.

Taper cutting

ROBOCUT comes with a range of features designed to reduce cycle times on taper cutting processes and guarantee continuous unmanned machining. These include advanced taper cutting compensation, FANUC's soft wire AWF and twin servo wire tension control.

Keyway cutting function

Input the data, push the button and create the program. Cutting keyways is that easy. Once the cycle has started, positioning and cutting are automatic, making this the convenient way to cut keyways.

Automatic soft wire function

Dispensing with the need for an operator to monitor the machine, soft wire AWF3 allows continuous unmanned machining on extended production runs thanks to extended electrode life.

3D rotation function

To ensure faster error-free set up, FANUC Auto 3D software measures inclination and rotation on the workpiece with touch probe to perform automatic compensation of the program plane and each axis movement – without the need for an additional 3D measuring machine and server (PC).

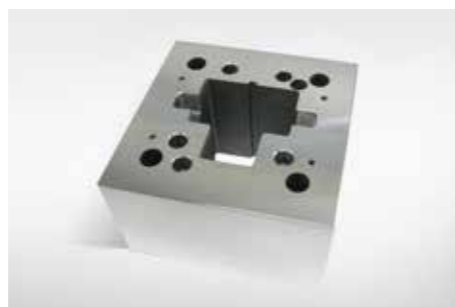

Customise your ROBOCUT

Designed to enhance the productivity of your ROBOCUT across an enormous range of applications, FANUC's range of dedicated software and hardware accessories give you the freedom to tailor your machining processes to your needs precisely. Like all FANUC products, FANUC accessories exhibit world-beating reliability, are simple to use and have been designed to help you get the most out of your ROBOCUT. Using them will allow you to increase output and maintain exacting quality standards regardless of how challenging your machining processes might be.



Programming made easy with ROBOCUT-CAMi

The FANUC ROBOCUT-CAMi system makes programming cylindrical, conical and 4-axis machining routines easy. You can mirror ROBOCUT-CAMi software directly to the CNC screen by using the remote desktop function. ROBOCUT-CAMi also offers multiple languages and a number of 2D or 3D data import options such as DXF, IGES and STEP files.

Your advantages with ROBOCUT-CAMi

- ROBOCUT-CAMi software can be mirrored to the CNC screen
- huge range of post-processing options
- simple program transfer via Ethernet interface
- automatic default settings reduce set up times
- simple programming of involute gearing, top and bottom shapes, coreless cutting
- flexible programming of CORE STITCH function
- programmed positions for robotic part loading and unloading



FANUC CCR table

For the best PCD tool making results, ROBOCUT is available with a CCR rotary table. This lightweight universal rotary table comes with high-resolution glass scales and, for maximum concentricity, provides optimum travel between the U and V.

Dimensions (LxWxH)	170x155x130mm
Mass of rotary table	16 kg
Indexing accuracy	16 sec.
Repeatability	± 2 sec.
Allowable mass of work piece	40 kg

ROBOCUT Accessories



AI thermal displacement compensation with 7 sensors

Thermal displacement compensation is also available with 7 sensors for ultimate thermal stability.



0.05 mm and 0.07 mm thin wire option

Finer than standard 0.1 mm wire, this is available as an option on C400iB only to produce very small and thin parts.



30 kg wire auto loader

Retrofittable for up to 140 hours of extended unmanned operation.



Renishaw touch probe

For precise automatic positioning and workpiece alignment.



Extended Z axis stroke

This option allows you to machine larger and thicker workpieces.

ROBOCUT C800iB → Z500

ROBOCUT C600iB → Z400



Option warning light

Three-stage LED light with buzzer to inform about operating status of machine.



Linear scale

for even more precise position control.



6- or 7-axis retrofit kits

Include servo amplifier, axis card, cables and a connection box.



Automatic front door

Time saving option that dispenses with the need to completely drain the water.



Auto grease lubrication system

Lubricates according to specification, reducing the need for manual maintenance (factory option).



ProfDia GTR programming software

For rotary and fixed cutting tools.



Wire cutter

For long hours of unmanned cutting.



Automatic 3D rotation function

To ensure faster error-free set up, FANUC Auto 3D software measures inclination and rotation on the workpiece compensating for the program plane and each axis movement – without the need for an additional 3D measuring machine and server (PC).



MF2 function

FANUC's MF2 micro finish generator not only enables you to achieve extremely fine surfaces and mirror finishes but also ensures maximum accuracy and efficient cutting.

Designed to save energy

ROBOCUT's FANUC-made CNCs, motors, amplifiers, generators and pumps are engineered to deliver the lowest possible energy consumption through the use of intelligent energy management. Every component has been chosen to provide the highest possible performance for the least possible energy. Additional smart features to reduce energy consumption further include power monitoring, sleep mode, LED lighting, inverter pumps and cooling and power regeneration.

Energy saving function



The energy saving function makes it possible to track precisely the amount of energy being consumed during machining or on standby. Power saving interventions such as switching off flushing or filter pumps can also be set, with features such as screen savers, sleep mode, auto start-up by timer and auto power off, all contributing to additional savings.

- lower energy consumption and costs
- reduce machine running costs
- increase the lifetime of the machine



Lower energy costs



FANUC Others

Power monitor

This energy saving feature provides an overview of how much energy is being consumed and shows where savings can be made.

Lower energy costs

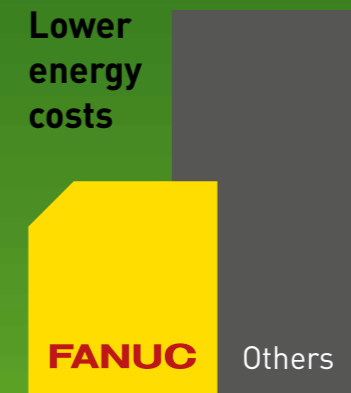

FANUC Others

Sleep mode

This feature saves energy by automatically putting the machine into sleep mode during periods of inactivity.

NEW

α -C800iB Technical Data



Standard	
Maximum workpiece dimensions [mm]	1250 × 975 × 300
Maximum workpiece weight [kg]	3000
XY axis table travel [mm]	800 × 600
Z axis travel [mm]	310
UV axis travel [mm]	200 × 200
Maximum taper angle [°/mm]	±30°/150
Minimum step increment of the drives [mm]	0.0001
Wire diameter [mm]	∅ 0.10 – ∅ 0.30
Maximum wire weight [kg]	16
Footprint (W/D) [mm]	2900 × 3260
Machine weight (approx.) [kg]	4200
Controller	FANUC 31i-WB
Part program storage size [MB]	4
Acoustic noise level	
LPA [dB]	64
LPCpeak [dB]	81
Optional	
Z axis 500	
Z axis travel [mm]	510
Maximum workpiece dimensions with automatic door, option Z axis travel [mm]	1250 × 975 × 500
Footprint [mm]	3300 × 3260
45° die guide	
Maximum taper angle [°/mm]	±45°/70
30 kg wire feed unit	
Maximum wire weight [kg]	30

Outer dimensions | Floor plan

- Power input position (200V AC, 3-phase)
- Compressed air input position
- * The values in parentheses < > are when the safety cover is open.

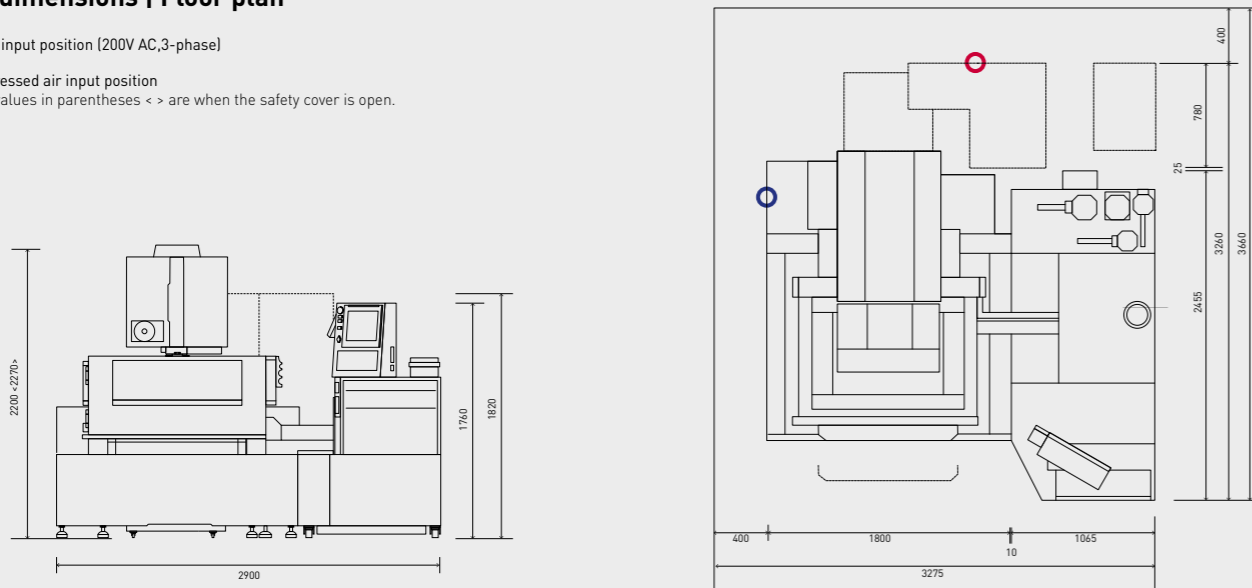

*] The above floor plan is that of a standard type machine. Contact FANUC if you wish to order options such as Z axis 500 and 30 kg wire feed unit.

α -C600iB Technical Data



Standard	
Maximum workpiece dimensions [mm]	1050 × 820 × 300
Maximum workpiece weight [kg]	1000
XY axis table travel [mm]	600 × 400
Z axis travel [mm]	310
UV axis travel [mm]	200 × 200
Maximum taper angle [°/mm]	±30°/150
Minimum step increment of the drives [mm]	0.0001
Wire diameter [mm]	∅ 0.10 – ∅ 0.30
Maximum wire weight [kg]	16
Footprint (W/D) [mm]	2440 × 2680
Machine weight (approx.) [kg]	3000
Controller	FANUC 31i-WB
Part program storage size [MB]	4
Acoustic noise level	
LPA [dB]	64
LPCpeak [dB]	81
Optional	
Z axis 400	
Z axis travel [mm]	410
Maximum workpiece dimensions without automatic door, option Z axis travel [mm]	1050 × 820 × 400
Footprint [mm]	2790 × 2680
Automatic front door (Standard machine only (Z axis travel = 310mm))	
Maximum workpiece dimensions [mm]	1050 × 775 × 300
45° die guide	
Maximum taper angle [°/mm]	±45°/70
30 kg wire feed unit	
Maximum wire weight [kg]	30

Outer dimensions | Floor plan

- Power input position (200V AC, 3-phase)
- Compressed air input position
- * The values in parentheses < > are when the safety cover is open.

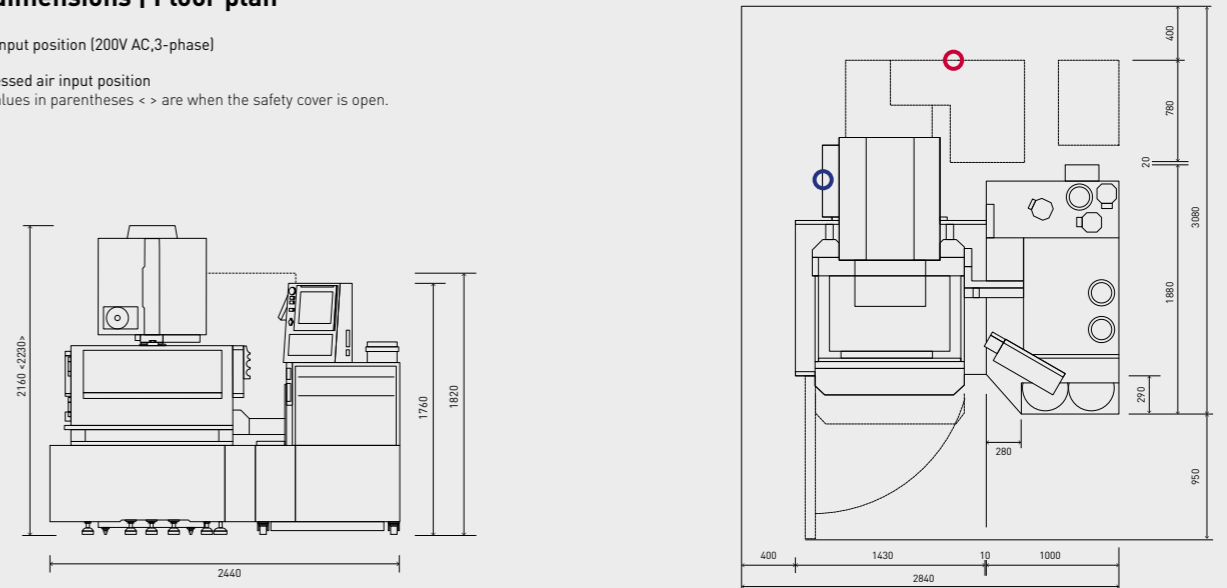

*] The above floor plan is that of a standard type machine. Contact FANUC if you wish to order options such as Z axis 400 and 30 kg wire feed unit.

α -C400iB Technical Data



Standard	
Maximum workpiece dimensions [mm]	730 × 630 × 250
Maximum workpiece weight [kg]	500
XY axis table travel [mm]	400 × 300
Z axis travel [mm]	255
UV axis travel [mm]	120 × 120
Maximum taper angle [°/mm]	±30°/80
Minimum step increment of the drives [mm]	0.0001
Wire diameter [mm]	Ø 0.10 – Ø 0.30
Maximum wire weight [kg]	16
Footprint (W/D) [mm]	1990 × 2200
Machine weight (approx.) [kg]	1800
Controller	FANUC 31i-WB
Part program storage size [MB]	4
Acoustic noise level	
LPA [dB]	64
LPCpeak [dB]	81
Optional	
Thin wire	
Wire diameter [mm]	Ø 0.05 – Ø 0.07
Automatic front door	
Maximum workpiece dimensions with automatic door, Z axis travel [mm]	730 × 585 × 250
45° die guide	
Maximum taper angle [°/mm]	±45°/40
30 kg wire feed unit	
Maximum wire weight [kg]	30

Outer dimensions | Floor plan

- Power input position (200V AC, 3-phase)
- Compressed air input position
- * The values in parentheses < > are when the safety cover is open.

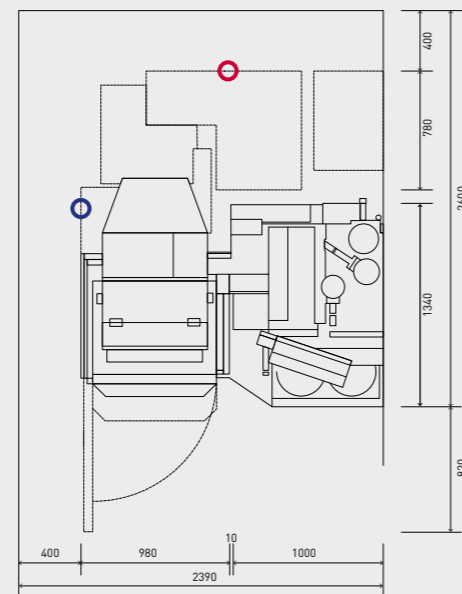
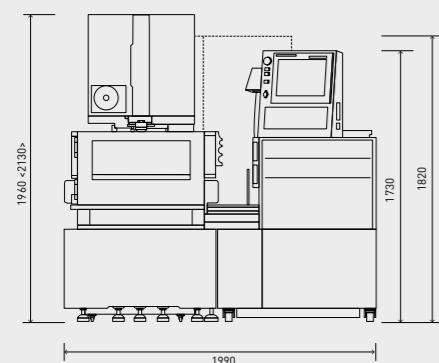

*] The above floor plan is that of a standard type machine. Contact FANUC if you wish to order options such as 30 kg wire feed unit and thin wire option.



Efficient FANUC service worldwide

Wherever you need us, our comprehensive FANUC network provides sales, support and customer service all around the world. That way, you can be sure you have always got a local contact that speaks your language.

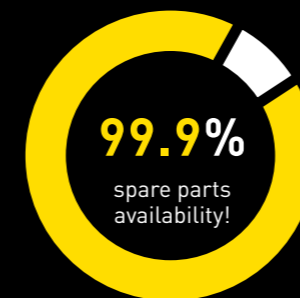

Efficient training: FANUC Academy

The FANUC Academy offers everything you need to upskill your teams and increase productivity – from introductory programs for beginners through to courses tailored to the needs of expert users and specific applications. Fast and effective learning, on-site training or cross machine training, make up the extensive educational offering.

WWW.FANUC.EU/SERVICE

Efficient long time productivity: FANUC Maintenance Services

To minimise impact on production and get the most out of your machine, we offer maintenance services designed to lower your machine's TCO. Whatever your production scenario, FANUC solutions keep your machine running via dedicated preventive, predictive and reactive maintenance procedures that maximise uptime and keep downtime to a bare minimum.

Efficient supply: Lifetime OEM spare parts

As long as your machine is in service we will provide you with original spare parts – for a minimum of 25 years. With more than 20 parts centres all over Europe, dedicated service engineers and direct online access to FANUC stores, availability checks and ordering, we keep you running whatever happens.

24/7
support

One common servo and control platform – Infinite opportunities **THAT'S FANUC!**



FA
CNCs,
Servo Motors
and Lasers

ROBOTS
Industrial Robots,
Accessories
and Software

ROBOCUT
CNC Wire-Cut
Electric Discharge
Machines

ROBODRILL
Compact
CNC Machining
Centres

ROBOSHOT
Electric CNC
Injection Moulding
Machines

ROBONANO
Ultra Precision
Machine